



**Imax
20-40kA**

Din Rail DC Power Surge Protector

DS2x0-xxDC Series



DS230S-48DC



The DS2x0-xxDC surge protector is designed to protect equipment connected to a DC power supply (or AC) against lightning surges.

These devices are based on high energy varistors (MOV) matched with the DC operating voltage (from 12 to 350 Vdc). The MOV are equipped with internal thermal disconnectors in order to provide safe end of life. The indication of the disconnection status is provided by a mechanical indicator and is transmitted through a remote signal mechanism. The pluggable module allows an easy and fast maintenance.

The DS2x0-xxDC is DIN rail compatible and is connected in parallel on the DC line to be protected.

Dimensions and Diagram (in mm)

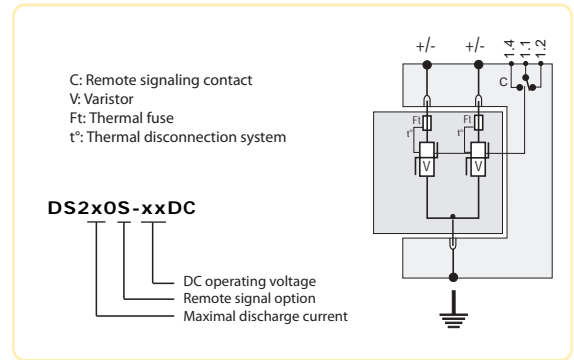
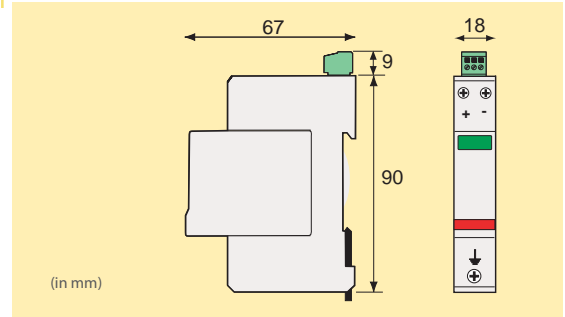

Characteristics

CITEL part number	DS220S-12DC	DS220S-24DC	DS230S-48DC	DS240S-75DC	DS240S-95DC	DS240S-110DC	DS240S-130DC	DS240S-220DC	DS240S-280DC	DS240S-350DC
Network voltage (Un)	12 Vdc	24 Vdc	48 Vdc	75 Vdc	95 Vdc	110 Vdc	130 Vdc	220 Vdc	280 Vdc	350 Vdc
Max. Operating Voltage (Uc)	24 Vdc	38 Vdc	65 Vdc	100 Vdc	125 Vdc	150 Vdc	180 Vdc	275 Vdc	350 Vdc	460 Vdc
Nominal discharge current (In)	10 kA	10 kA	15 kA	20 kA	20 kA	20 kA	20 kA	20 kA	20 kA	20 kA
Maximum discharge current (Imax) Max. 10/350 µs	20 kA	20 kA	30 kA	40 kA	40 kA	40 kA	40 kA	40 kA	40 kA	40 kA
Protection level (@ In) (Up)	250 V	250 V	300 V	390 V	450 V	500 V	620 V	900 V	1200 V	1400 V
Protective fuses (if necessary)	20 A	20 A	20 A	50 A	50 A	50 A	50 A	50 A	50 A	50 A
Thermal Disconnector	Internal									
Dimensions	see diagram									
Connection	by screw terminal - cross section 1,5-10mm ² (active wire) and 2,5-25mm ² (earthing wire)									
Disconnection indicator	2 mechanical indicator									
Remote signaling	(DS2x0S-xxDC) - by changeover contact									
Mounting	symmetrical rail (35mm)									
Operating temperature	-40/+85 °C									
Protection class	IP20									
Housing material	Thermoplastic UL94-V0									
NF EN 61643-11	France	Low Voltage SPD - Test Class II								
IEC 61643-1	Intl	Low Voltage SPD - Test Class II								
UL1449 3rd Ed.	USA/Canada	Type 4, Type 2 Location								
CSA C22.2 No. 8-M1986		Class 9091 32, Class 9091 92								